

BLDC PUMP

Automobile Water Pump



Rated Voltage: DC 12V/24V

Max Static Head: 6.5M / 8M

Max Flow rate: 5300LPH / 6300LPH

Input Power: 80W/120W

Inlet Outer Diameter: 38mm

Outlet Outer Diameter: 38mm

Size: 213.8x144x148mm

Weight: about 2000g

Material: PA66+30%GF

Waterproof: IP68

Noise: less than 40dB

Liquid Temperature: -40~125°C

Design special for the cooling system of the automobile battery, automobile engines, and motorcycle engines. Also suitable for other applications.

Main Features

- Sine Wave Silent Technology, Noise less than 40dB;
- Default with water shortage and stuck protection functions;
- Brushless DC motor, Magnetic Driven, Small size & High Efficiency;
- Long time continuous working, lifespan more than 20000 hours;
- Safety - no spark, Explosion-proof, IP68, 100% waterproof;
- Can be used to pump water, oil, acid and alkali solution.

BL-B02

Series

Model Code

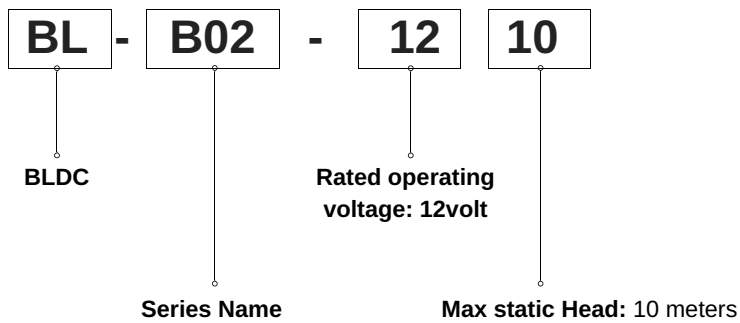

Mode List

Model	Voltage (V)	Current (A)	Max flow (L/H)	Max head (M)
BL-B02-1206	12	6.6	5300	6.5
BL-B02-2408	24	5.0	6300	8.0

Tips:

We offer customized service according to your specific needs at a reasonable price.

Performance Curve

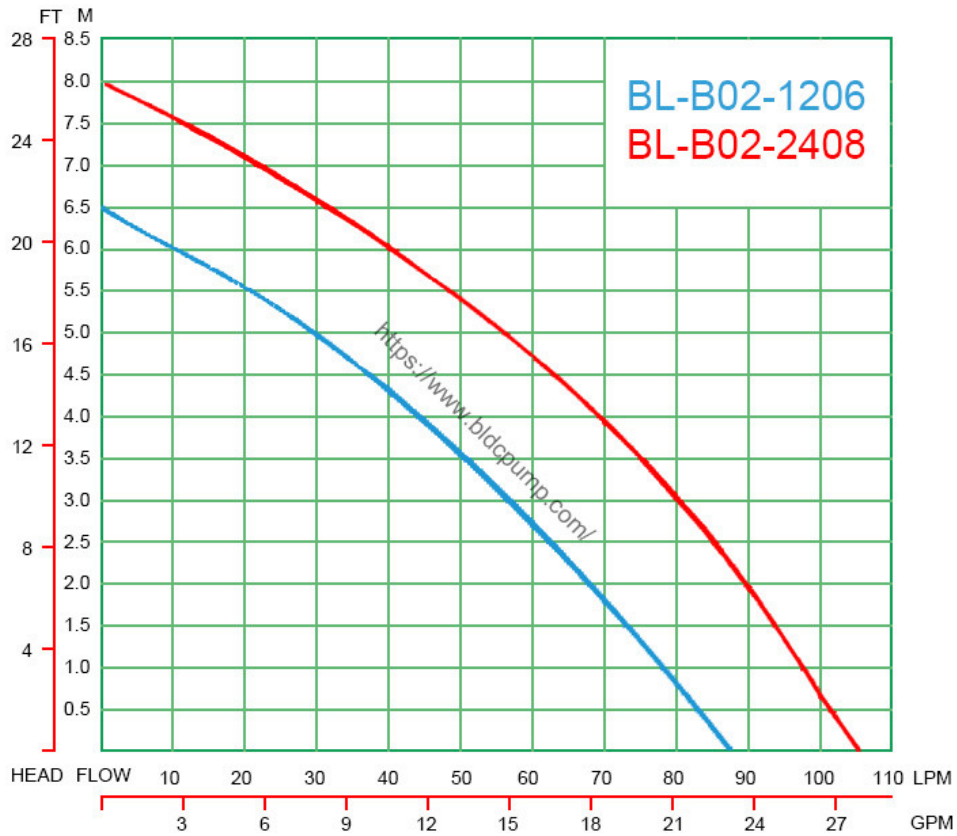

Dimensions

